

# Farnelli

COMPANY SPECIALIZING IN BUILT-IN OVENS  
AND HOBS

## BUILT-IN OVENS

### FEA 45 **SONATA**

FEA 45 SONATA  
FEA 45 SONATA WH

---

BUILT-IN  
ELECTRICAL  
OVEN



# OVENS

## Installation and operation instructions

### Dear Customer!

Thank you for purchasing a "FORNELLI" product. We hope, this appliance will meet your expectations and be a reliable assistant of yours in your kitchen. For correct and safe operation of the appliance, please carefully read all the chapters in the present manual. Keep your manual for the entire service life of the product you have purchased.

Reading the first part of the manual, you will learn some important conditions to provide for safe operation of the appliance. To keep your appliance in good condition for a long time, we offer you a lot of helpful advices on the product care and cleaning. In the manual there are some hints on energy saving.

On the last pages of the manual you can read recommendations which will help you remove minor failures, if any, during operation of your appliance.

Your new appliance is made of high-quality materials and fully conforms to any standard of the European Economic Community.

The manufacturer reserves the right to make changes to the product design in order to improve its performance. Our household appliances are subject to continual improvement, the performance is enhanced and their design is updated. Therefore, drawings and symbols in the manual may differ from those for the model you have purchased.

### Enjoy your meal!

The manufacturing date is in the serial number of the product. The serial number is on the internal label which is on the side of the oven. Serial number explanation **SPG/201408C/0001-50**:

**SPG / 201408C / 0001 - 50**

□ □ □ □ □

Code	year	month	order	number of this
	manufacturing		number in	specification
			the batch	in the batch

This example: the appliance was manufactured in August 2014.

---

### CONTENTS

#### SAFETY HINTS AND STATEMENTS

Connection requirements.....	2
Safety statements.....	2
How to avoid damage to the appliance .....	3
Energy saving advice.....	3

#### SCOPE OF SUPPLY AND TECHNICAL DATA

Scope of supply.....	4
Oven technical data.....	4

#### YOUR NEW OVEN

Oven use.....	5
Control console.....	5
Oven control elements .....	5
Electronic programmable device.....	6
Timer .....	8
Oven mode selection switch .....	9
Recommendations on roasting jack use .....	10
Thermostat .....	10

#### RECOMMENDATIONS ON FOOD PREPARATION

Hints on cooking.....	11
Hints on baking.....	11
Recommendations on food preparation .....	12

#### OVEN CARE

Oven care .....	13
-----------------	----

#### OVEN INSTALLATION

Oven installatio.....	14
Connection to the mains.....	16
Minor repairs .....	16
Replacement of lamps .....	17
Appliance disposal upon expiry of its service life .....	17

The product has been manufactured in line with European standards and is CE, TUV, ISO 9001 and EAC certified

### SAFETY HINTS AND STATEMENTS

**Attention! To avoid breakdown of the appliance, keep in unpacked at a room temperature within 2 hours at least prior to switching on in cold months.**

#### CONNECTION REQUIREMENTS

These are only qualified professionals who are permitted to mount and install the appliance, in compliance with the instructions and a connection diagram. The appliance shall be connected to a reliable grounding system to conform to valid standards of electrical safety.

The manufacturer disclaims all liabilities for damage to humans and property, if the appliance is not or improperly connected to a grounding system.

Prior to switching on the appliance, please check, if there are any foreign subjects inside the oven, such as packaging elements, etc. It is strictly prohibited to install and connect ovens with mechanical damages to components and power cables.

**Attention! Before the first use of the appliance we recommend you to heat the oven with a grid and baking pans placed at corresponding levels inside the oven and a maximum heating temperature set. Then, open the oven door, switch on the cooker hood and air the room to remove odors of lubricants that have been used for preservation of equipment during its storage time before installation. Then, you have to wash and wipe dry the oven and its components.**

#### SAFETY STATEMENTS

The appliance shall only be used for preparation of food, do not use it for heating the premises.

During operation, the appliance heats up. Its inner surfaces, heating elements and steam exit point become very hot. Do not let children stay near the appliance being used.

Stay close to the oven when cooking the food with use of fats or sun flower oil, because they can inflame when overheated.

The cables of electrical appliances must not touch hot elements of the oven. This may result in damage to wire insulation.

Upon occurrence of failures, cut off power supply tripping the automated circuit breaker.

No inflammable objects may be kept inside the oven. They may burn upon accidental powering on.

During long-term operation at high temperatures the door handle may also become very hot. Please, take care!

The continuous cooking time using the appliance shall not exceed 10 hours. Upon this time switch off the appliance and let it cool down completely!

### SAFETY HINTS AND STATEMENTS

#### HOW TO AVOID DAMAGE TO THE APPLIANCE

Do not cover dishes being cooked, do not place alu foils at the bottom of the oven, for that causes excessive accumulation of heat. As a consequence, the cooking time changes, and enamel of the appliance may be damaged.

Do not pour water into the hot oven – this can damage the enamel inside the appliance.

If you are going to bake a fruit cake, we recommend you to use a special tin, deep enough, because fruit juice dropping off the tin may mark the surfaces, and it is almost impossible to remove these stains.

Do not lean your elbows against and do not sit down on the oven door. The oven door must close firmly, please keep the door seal clean all the time.

These are only qualified professionals of the after-sales service who are permitted to repair the appliance, having a special work permit issued by the manufacturer. An independent repair or involvement of unauthorized persons may lead to occurrence of danger.

#### ENERGY SAVING ADVICE

1. If cooking takes a protracted period of time you may switch off the oven 10 minutes before the end of cooking time. The food will be cooked thanks to residual heat inside the apparatus.
2. Do not open the oven more often than required. Opening the door, you lose a large amount of heat, which, in turn, increases the cooking time.
3. You will optimally utilize the oven space, using oblong tins for baking, placed in parallel, at the same level, or baking at different levels at the same time.
4. Use dark or black baking tins. They are the best to resist the heat inside the oven.
5. Should you wish to cook food using a grill, place your food in the middle to achieve the best cooking results.

## Installation and operation instructions

### SCOPE OF SUPPLY\*

Your oven is classified as a built-in appliance.

The scope of supply includes as follows:

- Oven – 1 piece;
- Baking pan – 2 pieces;
- Grid – 1 piece;
- Roasting jack with a holder – 1 piece;
- User's manual;
- Set of self-tapping screws.

\* The scope of supply is subject to change without prior notice.

### TECHNISCHE DATEN DES BACKOFENS

Dieses Gerät entspricht den folgenden EWG-Standards:

- 73/23/EEC – nach Unterspannung;
- 89/336/EEC – nach elektrotechnischer Verträglichkeit;
- 93/68/EEC – nach Allgemeinstandards;
- 89/109/EEC – nach Materialien bzw. Objekten, die mit Lebensmitteln in Berührung kommen können.

Der Werkschild mit Angabe des Modells des Backofens, der Seriennummer und der Höchstleistung befindet sich auf der Oberfläche des Einbauteils bzw. auf der Frontseite des Gehäuses des geöffneten Backofens.

Net weight, kg: 29.

### Sizes of oven elements and its recess.

Oven total volume: 48 L; oven usable volume: 45 L.

Sizes of oven elements	Height	Width	Depth (Length)
Face panel size	594	447	21
Built-in part size	577	408	550
Recess used to build-in the appliance	600	410	575

### Electrical power of heating and other elements of the oven, maximum power consumption, Watt

Power-supply voltage: 220–240 V~, 50/60 Hz.

Energy efficiency class: A

Protection Rating: 1

Element	Power, W
Grill	2000
Upper heating element	1800
Lower heating element	900
Ring-type heating element	1600
Convector motor	13
Cooling motor	11
Oven illuminating lamp	25
Roasting jack motor	4
<b>Maximum power consumption</b>	<b>2736</b>

## Installation and operation instructions

## OVEN OPERATION

## CONTROL CONSOLE

1. The push-pull\* mode selection switch is used to select a cooking mode desired.
2. The electronic programmable device enables to set actual time, cooking duration and end of cooking. In some models it can also be used as a timer.

a temperature value, required for preparation of your dish, switch on the oven and start cooking after the control lamp is off. The lamp being off means the oven has been preheated to the temperature you have selected.

Fig. 1. Control console

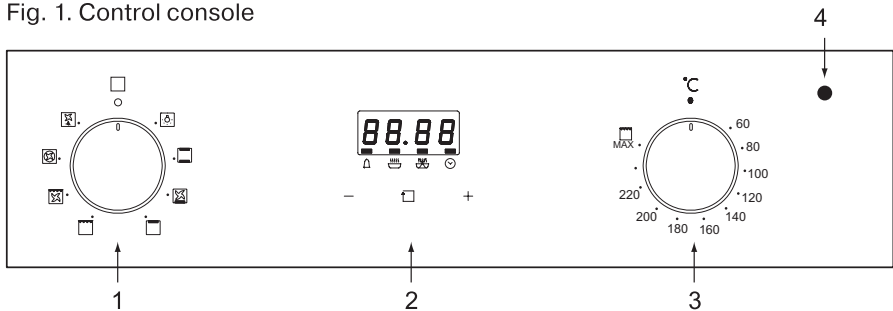

3. The push-pull\* temperature selector (thermostat) is used to set a temperature value required for cooking (temperature values ranging from 50°C to 270°C). The values of temperatures are indicated around the selector.
4. The heating elements operation control lamp (to indicate whether the heating elements are on / off to keep a chosen cooking temperature). The feature is convenient for preheating the oven. You select

## OVEN CONTROL ELEMENTS

Your new oven has a multifunction system used for preparation of food. This enables to select the best cooking mode for a dish you wish to cook. The mode required may be selected with switches on the control console.

To decrease the temperature of the external surface of the oven, built into a piece of kitchen furniture, the models are equipped with a cooling fan which is on, with any mode

\* The control knob is recessed into the console. To set a value required, you should do the following: press the knob to move it up, set a value desired, turning the knob clockwise / counterclockwise. Then, press the knob again to recess it.

## Installation and operation instructions

selected, after the temperature of the oven surface has reached a critical value. Upon switching on the cooling fan, you can feel the air flowing through the gap between the control console and the oven door.

Each mode of the oven, regardless of the design of switches, has a special symbol to designate it. On the control console they are presented as pictograms. Let us consider the purpose and positions of each switch.

## ELECTRONIC PROGRAMMABLE DEVICE

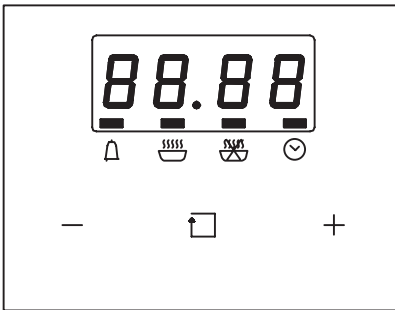



Fig. 2. Electronic programmable device.

The device consists of a display and symbols and control keys beneath it (Figure 2). The symbols have meanings as follows:

-  Timer
-  Cooking time
-  End of cooking time
-  Clock

The control keys perform functions as fol-

lows:

 A key used to decrease a displayed value.

 A key used to change modes. Repeated activation of the key results in switching to the next mode. The blinking rectangular symbol and the pictogram beneath that show the actual mode.

 A key used to increase a displayed value.

Upon connection of the oven to the mains, "12:00" will be displayed on the electronic programmable device, and the rectangular symbol above the pictogram  will be flashing. This is to show that actual time shall be set. befinet.

The actual time shall be set using keys "+" or "-". Upon selection of a time desired, press the mode selection button to enter the value or wait 5 seconds to automatically store the settings.

**Please, pay attention:** disconnecting the oven from the mains, you will have to set time again.





## Installation and operation instructions

## Settings for automated start and end of cooking

Should you wish to have any dish cooked to a given time and be sure that its cooking will take a certain amount of time, you can program the electronic device as you need. For that, you have to set the cooking time and end of it, using a method as follows:

- press the mode selection key several times to move the rectangular symbol on the display to a position above the symbol . Using the "+" and "-" keys set a time required for cooking. Store the value, pressing the mode selection key again.



- press the mode selection key several times to move the rectangular symbol on the display to a position above the symbol . Using the "+" and "-" keys set a desired time of cooking end. Store the value, pressing the mode selection key again.

- use the control knobs to set a required oven mode and cooking temperature. After the settings have been made, indicators above  and  will blink to show that the automated cooking mode has been set in a proper way.

Let us take an example: you know that cooking your dish will take 45 minutes. You want to have the dish cooked at 14:00 o'clock. You have made settings required as described above. At 13:15 the oven will switch on, the cooking will start, and the display indicators will blink. The oven will switch off sharp at 14:00. There will be a sound signal given, and the indicators will keep blinking. Press any key to turn off the sound signal. Turn the temperature and mode control knobs to the OFF position.



## Semiautomatic cooking

In this mode you can select one of the cooking methods.

1. You know that it will take a certain amount of time to cook a dish you want to cook. press the mode selection key several times to move the rectangular symbol on the display to a position above the symbol . Using the "+" and "-" keys set a time required for cooking. Set the temperature and the oven mode. The oven will start operating, at that the indicator above the symbol  will blink. At the lapse of the set time the oven will switch off, and a sound signal will be given.

The indicator  will keep blinking. Press any key to turn off the sound signal. Turn the temperature and mode control knobs to the OFF position.

**Attention:** the cooking time shall not exceed 10 hours.

2. You wish to have a dish cooked at a certain point of time. Press the mode selection key several times to move the rectangular symbol on the display to a position above the symbol . Using the "+" and "-" keys set a desired time of cooking end. Set the temperature and oven mode. The oven will switch on, and the indicator  will keep blinking. At a set point of time the oven will switch off, a sound signal will be given, but the indicator  will keep blinking. Press any key to turn off the sound signal. Turn the temperature and mode control knobs to the OFF position.

## Installation and operation instructions

**Attention!** The oven will switch on right after setting this mode, and the oven operating time will depend upon the off time you have programmed. Be careful: longer cooking time may result in burning of food and its spoilage. Due to special features of the display the end of cooking time can be set only before 23:59.

### Timer

The purpose of the electronic timer is to only give the sound signal. In the "Timer" mode, upon completion of the countdown, the heating elements will not switch off automatically. They will only switch off by turning the temperature and mode control knobs to the OFF position. The "Timer" mode is convenient because it reminds you on time and operates as an alarm clock. You can set a point of time at which a sound signal must be given within a range as follows: 00:01 – 23:59.

To set a timer value, press the mode selection key several times to move the rectangular symbol on the display to the position above



Use the "+" and "-" keys to set a time you desire. The countdown will start right after the setting has been made. Upon completion of the countdown, the sound signal will be

given, and the  indicator will keep blinking. Press any key to turn off the sound signal.

### Necessary additional information

Any mode of the electronic programmable device may be cancelled at any time. For that you have to use the mode selection key to select the function set and use "-" to set "00:00". Another method is to press and hold "+" and "-" at the same time.

Upon power cut, the functions of the electronic programmable device are no more stored. The actual time, as well as the other functions must be set and stored again.

## Installation and operation instructions

### OVEN MODE SELECTION SWITCH

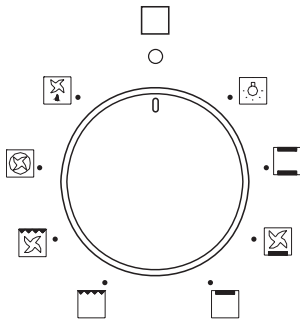

Fig. 3. Oven mode selection switch.

#### OFF



All the heating elements and illumination inside the oven are off.

#### LIGHT



All the heating elements are off, it is only the illumination which is on. This mode is convenient for preparation for cleaning the internal surfaces of the oven, to see what surfaces need cleaning.

#### Upper and lower heating



Upper and lower heating elements are in operation. The heat is uniformly supplied above and below onto dishes being cooked or fried. This is an ideal mode for baking bread, a sponge cake or fruit cake at the same level. This is also suitable for cooking lenten roast meat (veal and wild game).

#### Grill with convector



The grill heating element is in operation, and the convector is to distribute the heat throughout the entire volume.

#### Lower heating with convection



This is only the upper heating which is in operation. This is a perfect mode for especially thin bakery food.

#### Oberhitze



Nur das obere Heizelement ist in Funktion. Diese Funktion passt ideal für ein besonders dünnes Gebäck.

#### Grill



This is only the grill heating element that is on. It is in the upper part of the oven. This enables to thoroughly fry large quantities of food and is a perfect solution for beefsteak, chicken, turkey, fish and toasts.

#### 3D Konvektion



The fan and circular heating elements are on that are in the rear wall of the oven. The hot air circulates throughout the entire oven volume to produce uniform temperature at any level. One can cook various dishes - at several levels and at the same time, saving energy and time.

#### Defrosting



This is only the convector fan that is in operation. This is used to speed up defrosting and / or food drying by means of forced air circulation. The oven door must be at that closed.

## Installation and operation instructions

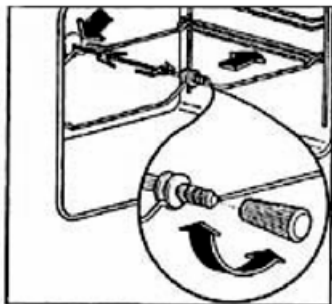
RECOMMENDATIONS ON USE  
OF ROASTING JACK

Its operation is combined with that of the grill. Put the food lengthwise, fix it using forks. After that do the following:

- insert the roasting jack end into the hollow shaft of the motor which is in the rear wall of the oven;
- install a support for the roasting jack grooves;
- unscrew the handle;
- place the fat pan at the lowest level;
- upon completion of cooking, screw the handle again and take the roasting jack out of the oven.

**Attention!** There is no separate control system for the roasting jack. Its motor automatically starts along with other modes. In this connection the roasting jack must be installed with the control handle in the OFF position.

## THERMOSTAT

Using this switch (Position 3, Figure 1), one can select a temperature inside the oven, at which the food is going to be cooked. The temperature is to be set by smooth rotation of the switch clockwise, within the range 50°C – 270°C. This is the oven heating control lamp to indicate whether the oven is heated to a given temperature (Position 4, Figure 1). If the lamp is on, this means, all the heating elements of the oven selected with use of the mode selection switch are on, and the oven has not been heated yet to a given value of temperature. As soon as the temperature inside the oven exceeds the given value, the heating element will be off, and the control lamp will be off, too. The thermostat keeps the given temperature, alternatively switching the heating elements on and off.

**Attention!**  
**REMINDER: your oven will NOT SWITCH ON with at least one of the two switches on the control console being in the OFF position!**

## HINTS ON COOKING

In the present manual you can find some recommendations on cooking time and temperature. More detailed information is presented in books on cooking. Please, be aware that the table data are specified for products being put into a cold oven. With an oven preheated, the cooking time decreases by 5 – 10 minutes.

Basing upon properties and amount of food to be cooked, as well as a level at which the food being cooked is going to be placed, the cooking time and temperature may vary.

## Installation and operation instructions

The table presents two methods of cooking the same dish. Each method description occupies three columns in the table. The data below are only approximate, because the cooking mode and cooking time may change, depending upon an amount and properties of the food.

**HINTS ON BAKING**

Baking temperatures and time depend upon an amount and properties of bakery dough. Therefore the table data are given as intervals. Start baking at lower temperatures presented in the table. Then, as it may be required, increase baking temperatures. Please keep in mind that lower baking temperatures always provide for uniform browning.

**Attention!**

**Tins shall be placed upon a grid at all times!**

**The cake top is burnt.** Place baked food at a lower level, decrease temperature and slightly increase the baking time.

**The cake bottom is burnt.** Place the baked food at a higher level. Set a lower temperature next time.

**You bake food at various levels (the “convection” mode is not at that used).** At higher levels the baked food are browner as opposed to lower ones. Select a slightly lower temperature which would result in more uniform baking. Foods being baked at different levels cannot be ready at the same time. Let the food being placed at the lower pan be baked 5 – 10 minutes longer or put that pan into the oven earlier than the others.

**Flat cookies “stick” to the pan surface.**

Place the pan into the oven again. Keep it there within a short time. Take the pan out. Now you can easily take them off.

**The cake remains within the tin even overturned.**

Use a knife to carefully separate the cake from the tin edge. Overturn it again. Use wet cold towels to cover it (several layers). Next time properly grease the tin and dredge it.

**You have measured the oven temperature using your own thermometer and found a temperature difference.**

The oven temperature is measured by the manufacturer using a test grid at the lapse of a certain time. The temperature is measured in the midpoint of the test grid. The type of used dishware and accessories also have impact upon measured values.

The values measured by you will always differ from the values set.

**How can one determine whether yeast-fermented dough has got baked thoroughly or not.**

10 minutes before the end of cooking time according to your recipe, pierce baked food using a wooden stick at the highest point. The food is ready, unless the dough sticks to the stick.

**The cake rises in the middle, but its edges are “fallen”.**

Do not grease the edges of a round-shaped tin. Upon completion of baking, use a knife to separate the cake from the tin. Water vapor may form during baking. Its greater amount escapes through the evaporation outlet. Vapors may condense upon tiles and furniture pieces close to the oven. This physical phenomenon is quite normal.

## Installation and operation instructions

## TIPS FOR THE PREPARATION OF FOOD

	Temp. °C	Position/ level	Cooking time	Temp. °C	Position/ level	Cooking time
Biscuit	180	3	20-25	160	1 or/and 3	25-30
wheat flat bread	230	4	10-15	210	1 or/and 3	10-15
small biscuits	180	3	15-20	160	1 or/and 3	15-20
torteletts	200	3	30-45	180	1	35-45
glaze torteletts	200	3	20-30	180	1 or/and 3	25-35
torteletts with brandy	230	4	15-30	210	1 or/and 3	20-35
cookies	200	3	10-15	180	1 or/and 3	15-20
loaf	220	2	20-40	200	1	25-45
lasagne	200	3	30-40	180	1	35-45
pizza	220	1	20-25	200	1	25-30
beef	200	2	20-30	180	1	20-30
pork meat	200	2	30	180	1	30-35
mutton	190	2	25	170	1	25
chicken	190	2	20	170	1	20-25
duck	190	2	30	170	1	35
goose	190	2	20	170	1	25
turkey	170	1	20	160	1	25
vegetables	200	3	30-40	180	1	35-45
meat quiche	160	2	2-3 hours	150	1	2-4 hours

## Installation and operation instructions

### CATALYTIC PANELS

Onto the surface of the farther wall of the oven a layer of self-cleaning, catalytic enamel is applied. Self-cleaning carries during the oven operation. But in fact, some badly-burnt stains can only be removed upon repeated operation of the oven.

Residues of flavors can easily be removed using a soft cloth or a brush.

Slight changes to the enamel color have impact upon its self-cleaning properties.

### OVEN CARE

#### **Attention!**

**Before cleaning, wait till the oven cools down. Disconnect the oven, unplugging it or tripping the switch.**

Do not clean the appliance using steam, do not practice power wash.

It would be fair enough to wipe the external surface of the appliance with a piece of wet cloth. If this is not sufficient, use a detergent agent or warm soapy water. With severe contaminations, not being removed by means of ordinary detergent agents, use special-type cleaning foam for ovens. Cleaning agents shall be only applied onto enameled surfaces.

In no circumstances use abrasives because they leave scratches and dead spots. If you happened to accidentally use them, wash them off with water immediately.

Baking pans can be washed with a soft sponge, using a dishwashing detergent, or in a dishwasher. To wash chrome-plated guides for baking pans also use a dishwashing detergent and a soft sponge. To remove badly-burnt stains use a harder sponge. Upon cleaning, wipe the surface with a dry piece of cloth. For easier cleaning you may take off the oven door (Figure 4).

For that, fully open the door. Snap the hook "B" of the door hinge "A" from its normal position to the rearmost one, on both hinges. Open the door in such a way so that the hooks "B" bump up against the edge of recess in the oven door.

## Installation and operation instructions

Pull the door up and push. With the door lifted to a sufficient height, take hinges out of their seats in the oven body.

The door shall be mounted in reversed order.

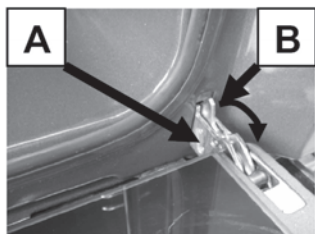

Fig. 4

## OVEN INSTALLATION

**Attention!**

**These are only qualified experts who are permitted to install the oven. The oven shall only be connected to the mains with the power cut off. The same applies to performance of any works with electrical components of the oven.**

Should the oven be installed in close vicinity to other electrical appliances located in the kitchen, make sure they will not interfere with each other. Before the first use please check whether you have removed all the protecting films used for transportation of the appliance.

**Attention!**

**Do not touch the door-locking hooks when the door is being removed. Do not place heavy objects upon the door, do not stand on it. This may lead to the door damage or injuries of the user. Do not use the oven, until the door is properly mounted again.**

Surfaces of kitchen furniture items, adjoining the oven, shall resist temperatures of up to 1000°C. Otherwise they may be damaged or deformed due to exposure to high temperatures. If your furniture is not designed to temperatures like that, we recommend you to use heat-insulating face plates to be laid onto walls of the furniture items. You can order and purchase these heat-insulating face plates at agencies selling kitchen furniture.

The manufacturer disclaims any responsibility for damage to humans or property resulting from improper installation of the oven or its misuse.

Prior to installation, make sure that a recess in the kitchen furniture, meant for your oven, has dimensions corresponding to those in Figure 6.



## Installation and operation instructions

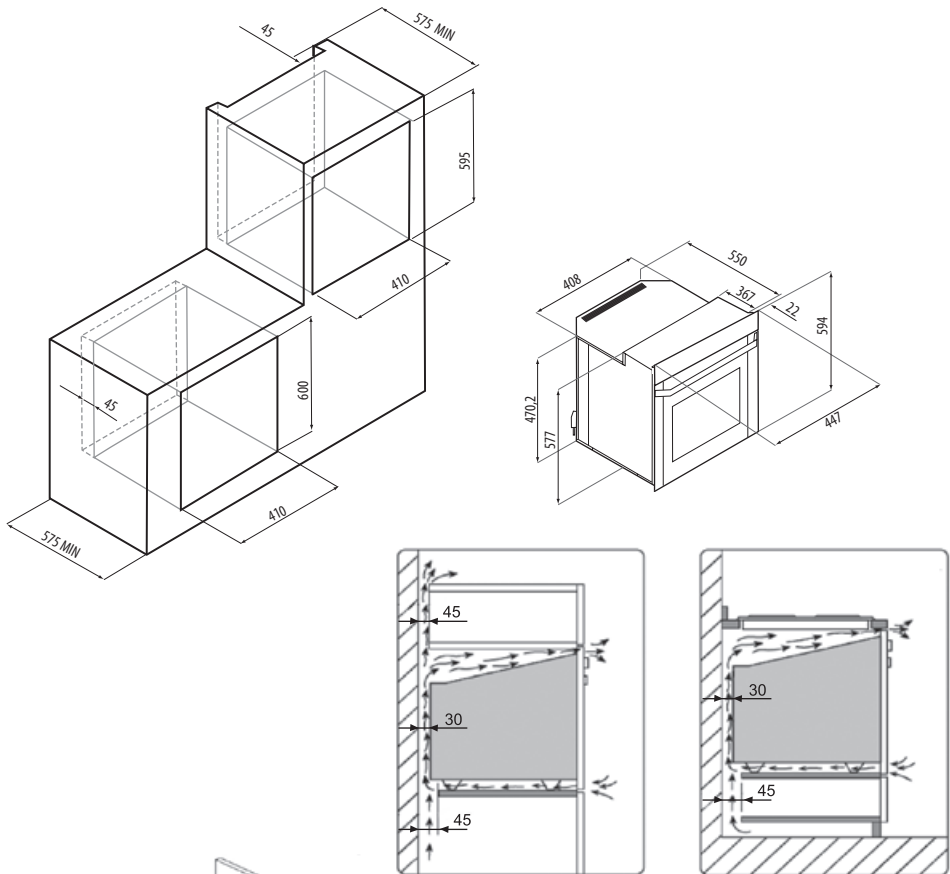

Fig. 6. Oven building-in diagram.

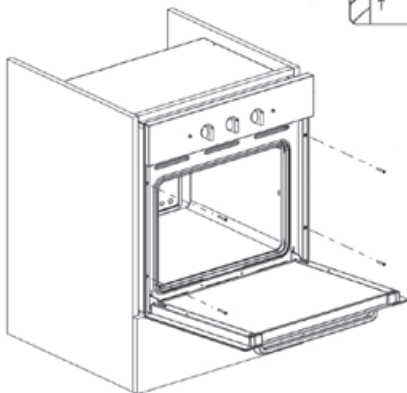

Fig 7. Attaching the oven to the furniture

# OVENS

## Installation and operation instructions

In the recess, between the rear wall and a rack, onto which the oven will be placed, there must be a gap, of minimum width 45 mm, to provide for proper ventilation. To prevent any damage and overheat, there must be another gap, minimum 30 mm, between the oven and the rear wall of a piece of furniture item.

The oven can be built-in into a standard opening, as shown in Figure 6, both under the tabletop and within a column.

To attach the oven to the furniture, use 4 screws which are within special openings in the frame (see Figure 7).

Be careful placing the oven into the opening, do not use the door as a leverage. Use special transportation handles.

### CONNECTION TO THE MAINS

Make sure that voltage and frequency of the mains conform to the values indicated in the manufacturer's plate. This plate is at bottom of the oven face panel. You can see that, if you open the oven door.

The appliance is designed for the mains operational parameters as follows: 220 – 240 V, one-phase current of 50 / 60 Hz frequency.

The electrical connections shall also include a ground contact.

After you have built-in and connected the oven, make sure that a socket that is going to be used for connection to the mains is easily accessible.

The product scope of supply also includes a power cable. That shall be equipped with a plug to resist a load as stated in the technical data table. If it turns out, for some reason or other, that the cable length is not sufficient, a qualified expert is permitted to replace the cable with a longer one, but it is expressly prohibited to splice the cable. Selecting a cable, pay special attention to its thermal resistance and cross-section.

### MINOR REPAIRS

Trouble	Possible causes	Instructions and remedies
The oven is out of order	Fuses blown-out	Check fuses in the electric service panel
	Power cut	Check whether power is supplied to the kitchen
Condensate between glasses of the oven door	Excess moisture content in the kitchen	Wipe the lower section of the oven door to prevent damage to the kitchen furniture

## Installation and operation instructions

### LAMP REPLACEMENT

To illuminate the inside of the oven, a special, high-temperature lamp is used (T 300°C, lamp base E14, wattage 25 W).

**ATTENTION! Cut the power prior to replacing the lamp.**

Remove the globe and unscrew the burnt-out lamp. Screw another one, of similar data. Mount the globe (Figure 8).

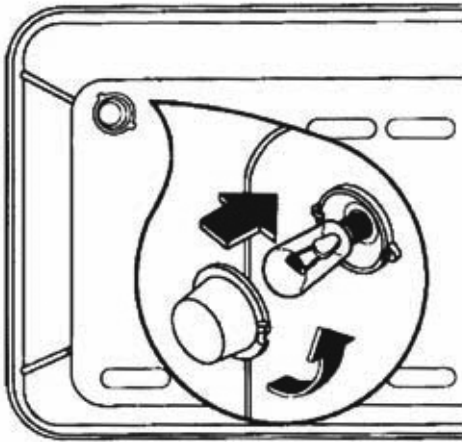

Fig. 8. Lamp replacement

### APPLIANCE DISPOSAL UPON EXPIRY OF ITS SERVICE LIFE

The present appliance shall not be disposed as domestic household waste. Instead, it shall be delivered to a licensed electric and electronic waste disposal and collection point. Following the waste disposal regulations, you will help prevent potential damage to the environment and humans which would otherwise occur due to inappropriate handling of the wastes of that type. For more detailed information on disposal of your appliance please contact local authorities, waste collection and disposal services or a sales agency where you have purchased the product.



Prior to disposal keep the appliance away from children.

To prepare the product for disposal, unplug it and make the cable and plug inoperable (for that, you can cut the cable, for instance). In such a way you will prevent further unauthorized use of the appliance.

### STORAGE

Keep the appliance in a dry place, away from sources of high temperatures and sunlight. During storage avoid rapid temperature changes. Storage of an unpackaged product is not permitted.

### TRANSPORTATION

Package dropping and any mechanical impact upon it are strongly prohibited.

# Warranty service conditions

The products are subject to free repair, if used only for personal, family or other needs, not related to business activities, or satisfying household requirements in an office of a company, institution or enterprise. The use of the products for purposes differing from above is deemed violation of the operation regulations.

The warranty certificate confers a right on free repair of the product within 12 months from the purchase date. Should you have any questions regarding the maintenance service, please contact the official representative of the brand. The contact details are on the web site of our partner kroona-steel.com. Within the warranty period defective parts of the products are subject to free repair or replacement with new ones. It is the Service Center that has to decide whether the defective products shall be repaired or replaced.

The service life of the product is 7 (seven) years. The service life starts on the purchase date. If it turns out to be impossible to determine the purchase date, the service life shall start on the manufacturing date, encoded in the product serial number which is on the manufacturer's plate.

The manufacturer's plate availability is an obligatory condition! Make sure it is available and keep it for the entire service life of the product. If it is not available, it may turn out impossible to determine the product model, manufacturing date. As a consequence, a request for a free repair may be declined.

The free repair is only possible with a properly and duly filled in warranty certificate, sale receipt for a product purchased, other documents to confirm the warranty period of the product submitted for repairs or diagnostics.

When buying a product, make sure the warrant certificate is duly filled in, contains no corrections and bears the purchase date, the stamp of a sales

agency and signature of a sales assistant (including a tear-off card), model and the serial number of the product.

Before you call a Service Center specialist, please carefully read the operation regulations. If the product turns out to be non-defective upon diagnostics performed by the specialist, the Service Center reserves the right to demand an ungrounded call payment from the customer, basing upon the current price list.

For your safety, these are only licensed and authorized specialists and companies who are permitted to carry out installation and connection of gas operating equipment.

Please keep receipts and other documents with regard to installation and connection of your product for its entire service life.

Any complaints with regard to quality of the components are subject to consideration only upon the quality inspection (technical condition inspection) to be conducted by a representative of the authorized Service Center.

Kõik pretensioonid toote kvaliteedi ja detailide kompleksuse suhtes vaadatakse läbi pärast (tehnilise olukorra) kvaliteedikontrolli hoolduskeskuse autoriseeritud esindaja poolt.

The manufacturer shall not be liable for any damage to a customer or property of a customer and not be obliged to perform free repairs on the occurrence of any of the following:

- documents are missing to confirm the right for free repairs;
- repairs have not been performed by authorized persons, the product design has been changed, the product intervention is found, conflicting with the operation regulations;
- the operation regulations have been violated, stated in the product manual;

---

\* Except backlight lamps, unless its replacement procedure is described in the operation manual. It is only the replacement procedure that is free, not the lamp itself.

## Warranty service conditions

- installation regulations have been violated, as stated in the product manual;
  - the product has not been timely serviced and maintained, as the product manual requires;
  - the components and consumables have been replaced (accessories, lighting lamps\*, filters, catalyst pads, plates, roasting jacks, grids, dishes and holders for microwave ovens, remote control devices, accumulators, batteries, etc., plastic parts handled manually);
  - consumables have been used, of improper quality;
  - defects and damages have been found caused by extreme conditions and force majeure circumstances (fire, Acts of God, etc.);
  - impact of water and solutions upon mechanical and electrical components of the product;
  - negligent storage and / or negligent transportation have been proved;
  - damages (failures) of the equipment, its malfunction due to animals or insects;
  - remains of food being cooked inside the product;
  - mechanical damage to the product (scratches, cracks, spalls, etc.);
  - loss of the saleable condition due to impact of chemicals;
  - use of cleaning / detergent agents, non-conforming to the type of the product;
  - thermal, mechanical and other damage of that kind that appeared while in operation;
  - the product uninstallation by a specialist of the Service Center turns out to be impossible (complex uninstallation procedures are subject to reassignment to the company that has installed the product);
  - unintended use of the product;
  - the warranty terms and conditions have been violated, as stated in the warranty document.
- The following is not subject to warranty services: adjustments, installation, cleaning and connection.





*Fornelli*

[www.fornelli-tech.com](http://www.fornelli-tech.com)